



# Cadet European Judo Cup Gyor 2017

(HUN Gyor, 1819 Nov. 2017)

## -50 kg

9 Judoka

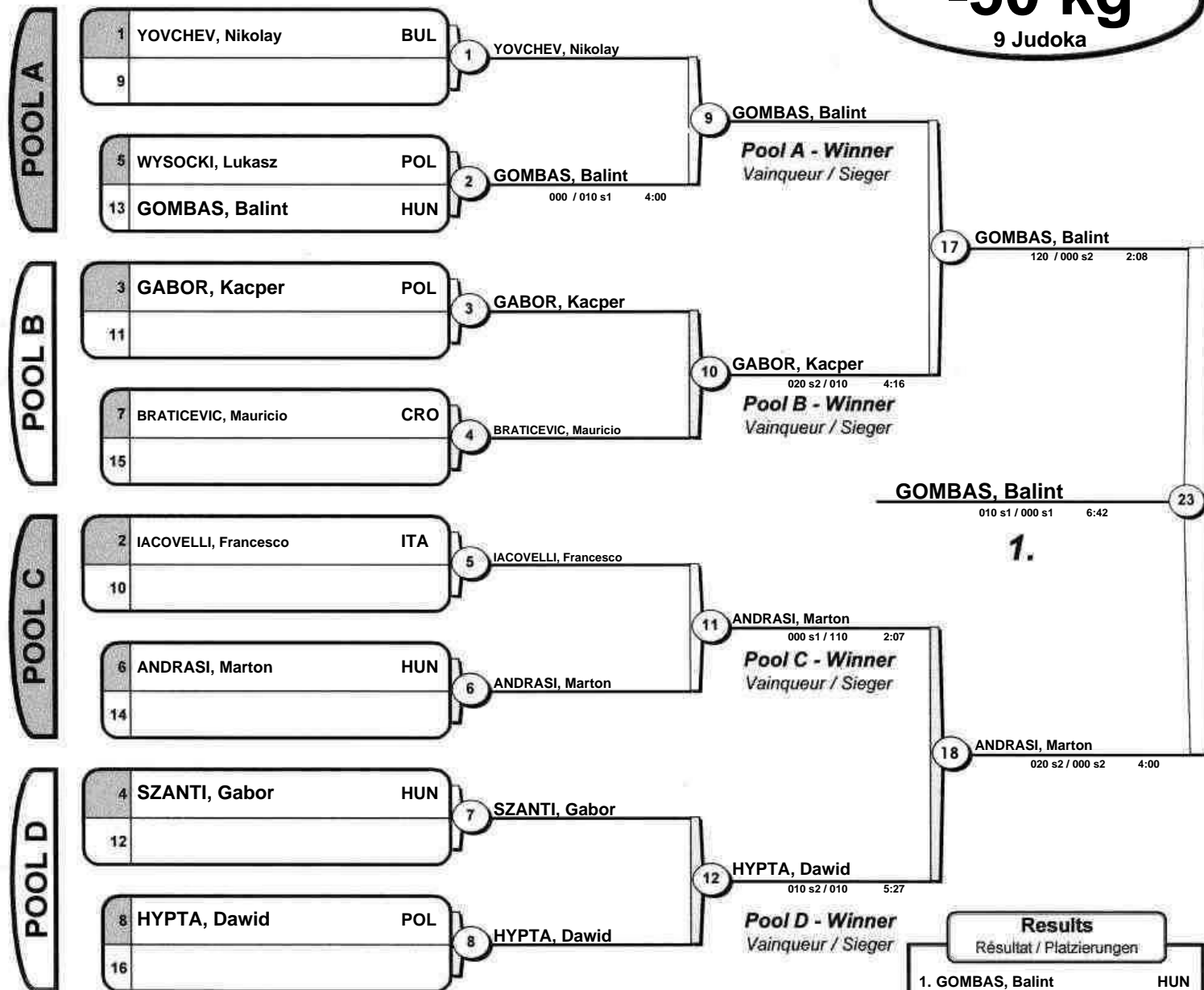

Results	
Résultat / Platzierungen	
1. GOMBAS, Balint	HUN
2. ANDRASI, Marton	HUN
3. YOVCHEV, Nikolay	BUL
3. SZANTI, Gabor	HUN
5. HYPTA, Dawid	POL
5. GABOR, Kacper	POL
7. BRATICEVIC, Mauricio	CRO
7. IACOVELLI, Francesco	ITA

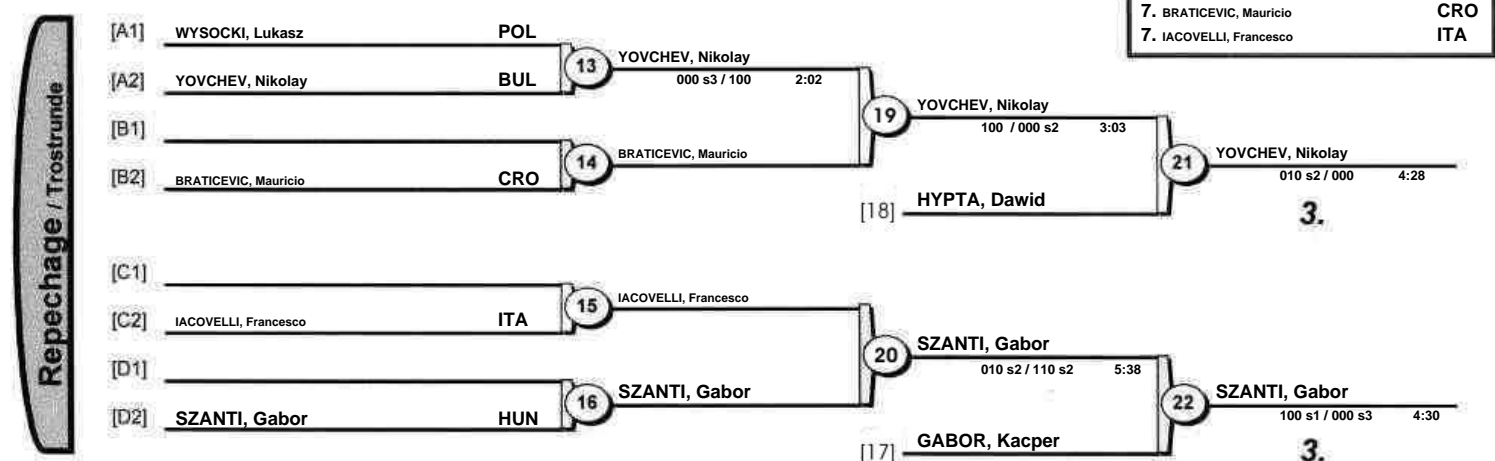



# Cadet European Judo Cup Győr 2017

(HUN Győr, 1819 Nov. 2017)

## -55 kg

29 Judoka

POOL A

1	LEUTGEB, Daniel	AUT	1	LEUTGEB, Daniel	
17					
9	RESEIGH, James	GBR	2	FECZKO, Csanad	000 / 010 4:00
25	FECZKO, Csanad	HUN			
5	BUESSEMEYER, Tom	GER	3	BUESSEMEYER, Tom	120 / 010 2:30
21	MEDVIDOVIC, Marin	CRO			
13	VIKOL, Andras	HUN	4	VIKOL, Andras	100 / 010 s1 2:42
29	PETRESCU, Eduard	ROU			

**Pool A - Winner**  
Vainqueur / Sieger

POOL B

3	KOLASAU, Artsiom	BLR	5	KOLASAU, Artsiom	110 / 000 1:08
19	KUBICKI, Jakub	POL			
11	BALOGH, Laszlo	HUN	6	VOPAT, Jan	000 s1 / 030 4:00
27	VOPAT, Jan	CZE			
7	SZEGEDI, Daniel	HUN	7	SZEGEDI, Daniel	110 / 000 1:12
23	KLAUS-STERNWIESER, Alexander	AUT			
15	RAFANIELLO, Luca	ITA	8	RAFANIELLO, Luca	020 / 000 s1 4:00
31	COVACIU, Dan	ROU			

**Pool B - Winner**  
Vainqueur / Sieger

POOL C

2	RADVANSZKI, Adam	ROU	9	RADVANSZKI, Adam	100 / 000 0:59
18					
10	WAIZENEGGER, John	FRA	10	WAIZENEGGER, John	100 / 000 sH 3:00
26	MAROSI, Balint	HUN			
6	DOLEZAL, Michal	CZE	11	ANDRASI, Gellert	000 / 100 2:21
22	ANDRASI, Gellert	HUN			
14	RIEGER, Julian	AUT	12	KUNZE, Nicolas	000 s2 / 010 s1 4:00
30	KUNZE, Nicolas	GER			

**Pool C - Winner**  
Vainqueur / Sieger

POOL D

4	DI CAPUA, Daniele	ITA	13	DI CAPUA, Daniele	000 / 100 1:29
20					
12	RECHBERGER, Nikolas	AUT	14	RECHBERGER, Nikolas	110 / 000 s2 3:15
28	MAUKS, Akos	HUN			
8	MERTL, Daniel	CZE	15	DZVONIK, Uladzislau	000 / 120 1:30
24	DZVONIK, Uladzislau	BLR			
16	RUEBO, Jano	GER	16	RUEBO, Jano	100 / 000 2:28
32	TARNAI, Kevin	HUN			

**Pool D - Winner**  
Vainqueur / Sieger

KOLASAU, Artsiom  
010 s1 / 000 s2 4:00

1.

RECHBERGER, Nikolas  
000 / 010 4:10

Results	
Résultat / Platzierungen	
1.	KOLASAU, Artsiom BLR
2.	RECHBERGER, Nikolas AUT
3.	LEUTGEB, Daniel AUT
3.	FECZKO, Csanad HUN
5.	RADVANSZKI, Adam ROU
5.	DZVONIK, Uladzislau BLR
7.	RAFANIELLO, Luca ITA
7.	WAIZENEGGER, John FRA

Repechage / Trostrunde

[A1]	RESEIGH, James	GBR	29	LEUTGEB, Daniel	000 s2 / 110 2:28	33	LEUTGEB, Daniel	100 / 000 0:55
[A2]	LEUTGEB, Daniel	AUT						
[B1]	KUBICKI, Jakub	POL	[A3]	BUESSEMEYER, Tom				
[B2]	VOPAT, Jan	CZE	30	KUBICKI, Jakub	100 s1 / 000 s1 5:25	34	RAFANIELLO, Luca	000 s1 / 020 4:00
[C1]			[B3]	RAFANIELLO, Luca				
[C2]	WAIZENEGGER, John	FRA	31	WAIZENEGGER, John	010 / 000 s2 4:00	35	WAIZENEGGER, John	010 / 000 s2 4:00
[D1]	MAUKS, Akos	HUN	[C3]	KUNZE, Nicolas				
[D2]	DI CAPUA, Daniele	ITA	32	MAUKS, Akos	100 / 000 1:07	36	DZVONIK, Uladzislau	000 / 100 0:21
			[D3]	DZVONIK, Uladzislau	010 / 110 s1 3:41	37	FECZKO, Csanad	000 / 140 2:33

3.

3.



# Cadet European Judo Cup Gyor 2017

(HUN Gyor, 1819 Nov. 2017)

## -60 kg

39 Judoka

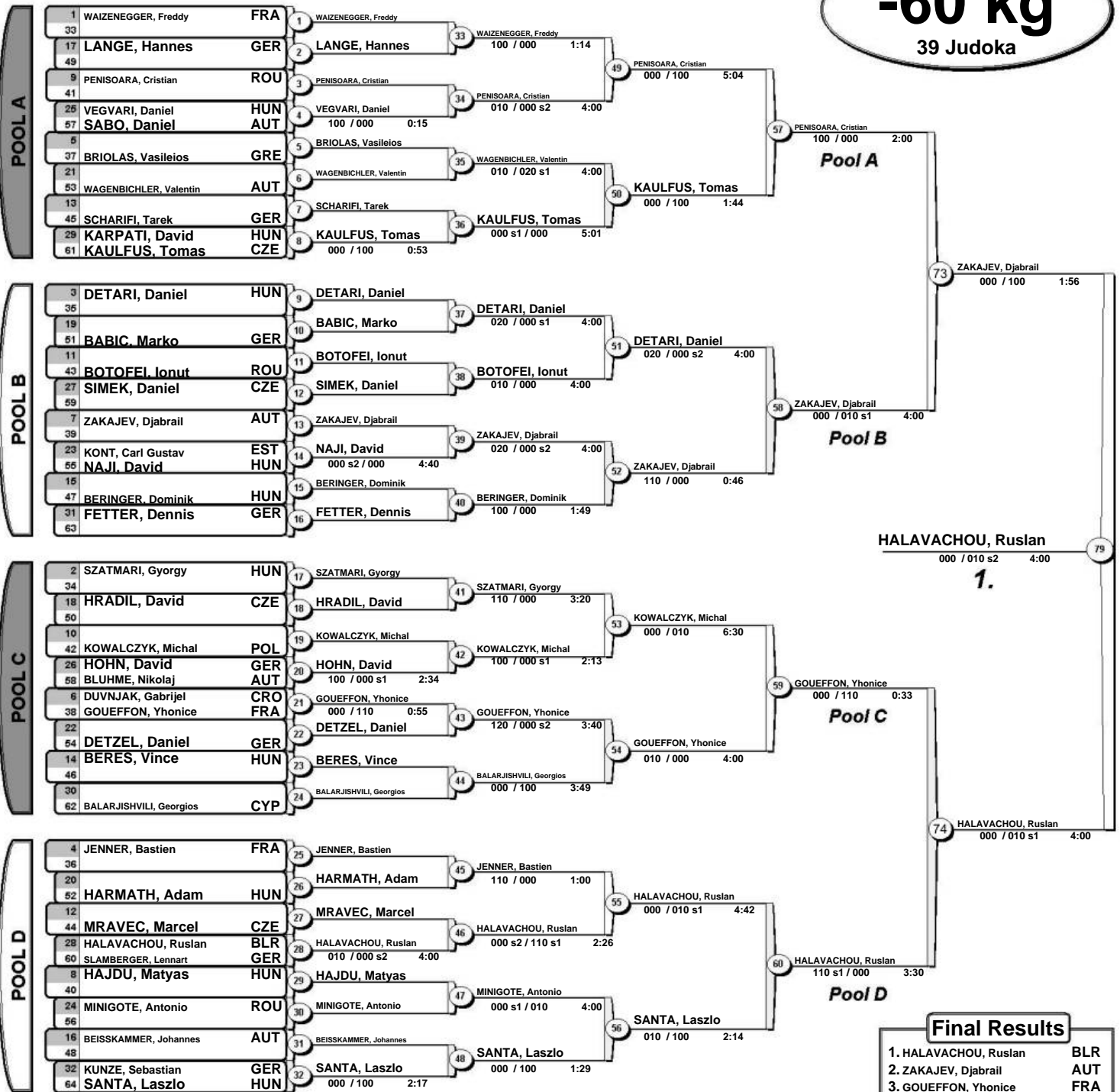

## Repechage

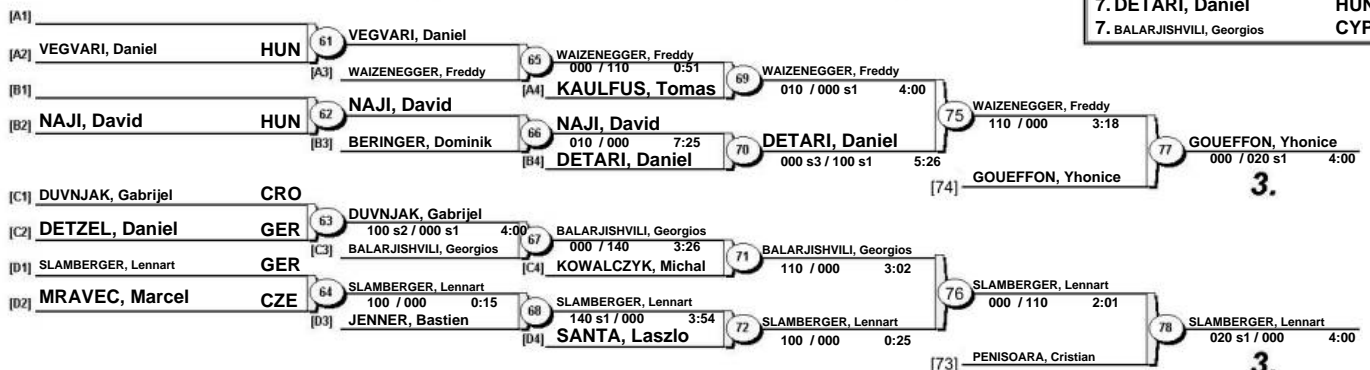





# Cadet European Judo Cup Győr 2017

(HUN Győr, 1819 Nov. 2017)

**-66 kg**  
37 Judoka

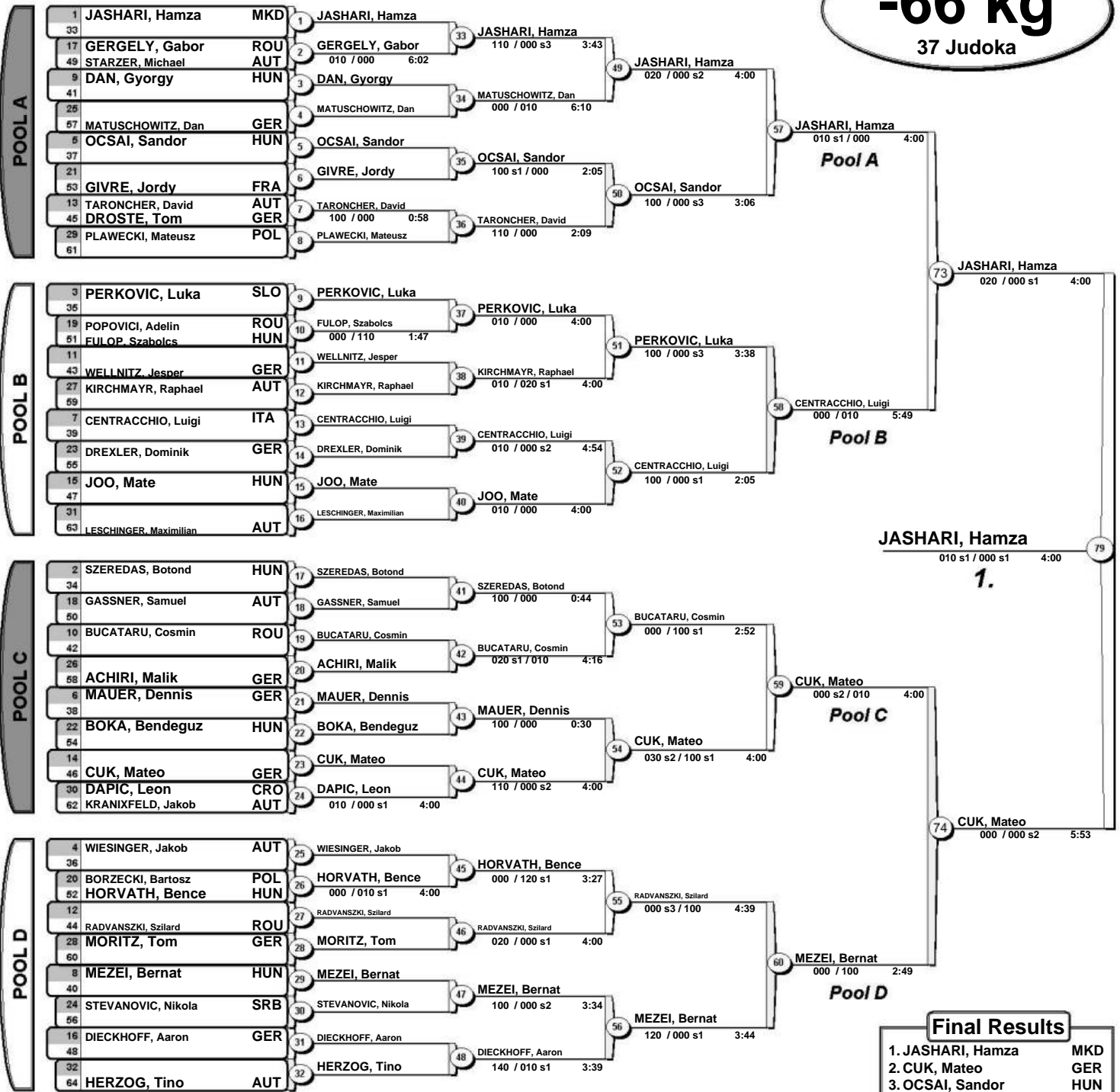

## Repechage

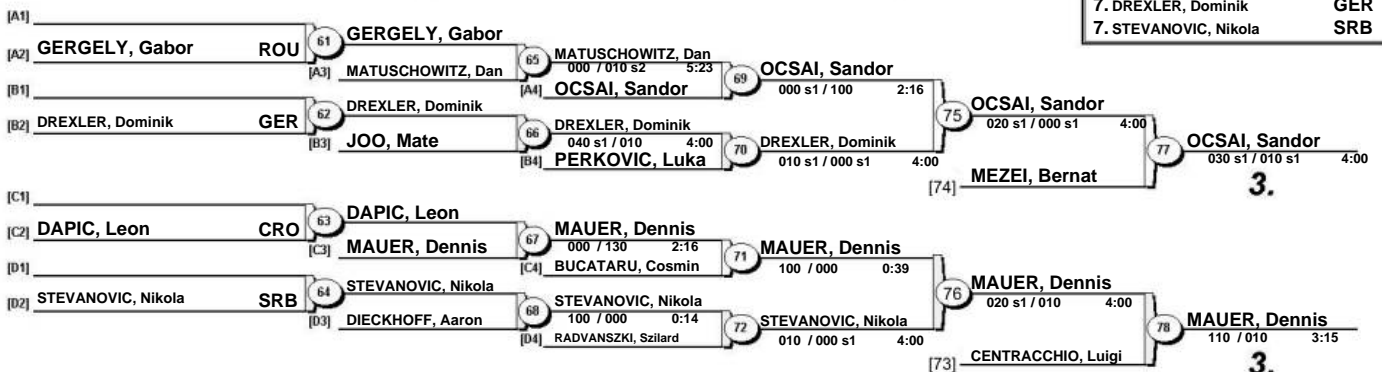



# Cadet European Judo Cup Győr 2017

(HUN Győr, 1819 Nov. 2017)

## -73 kg

33 Judoka

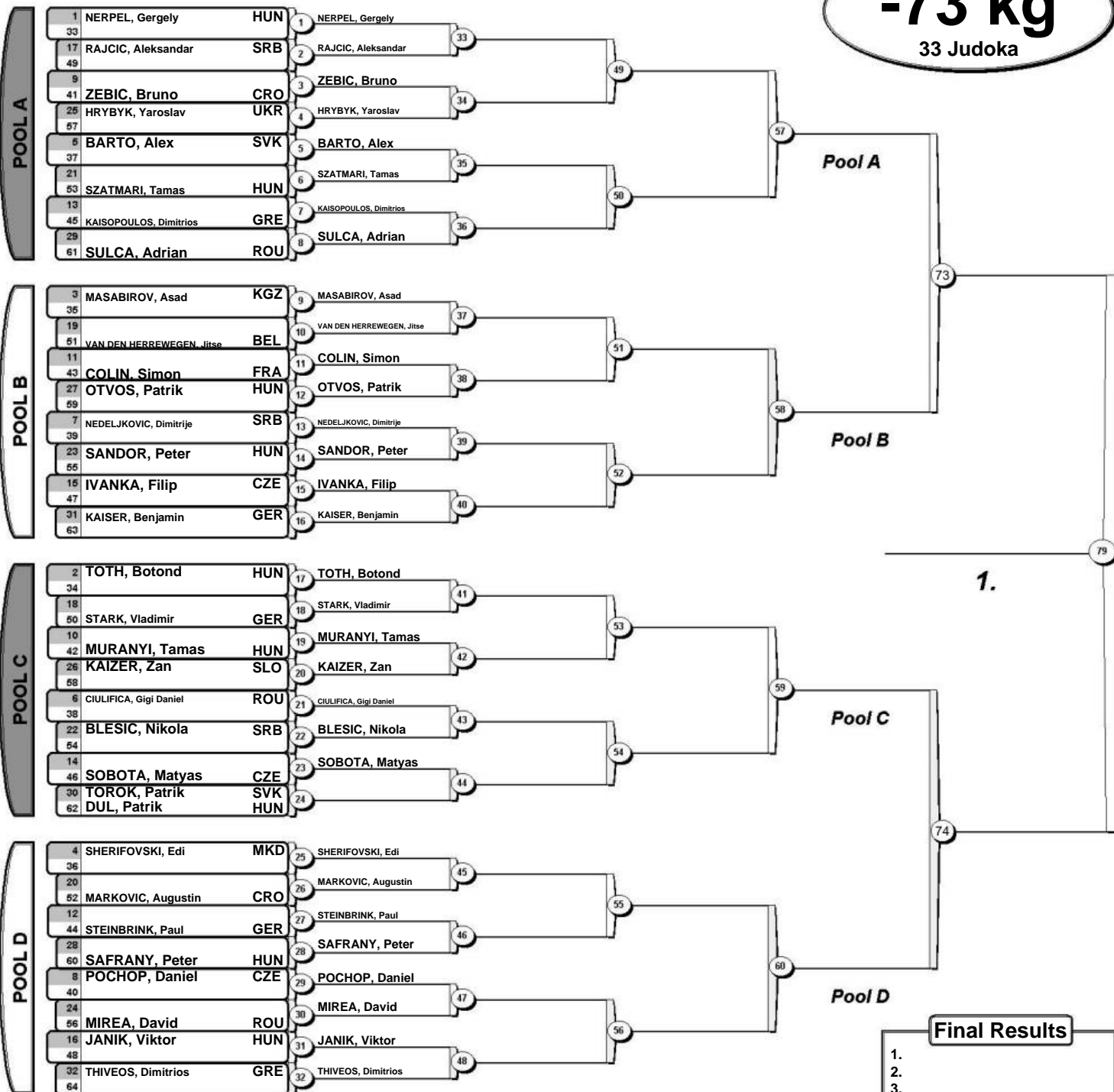

### Repechage

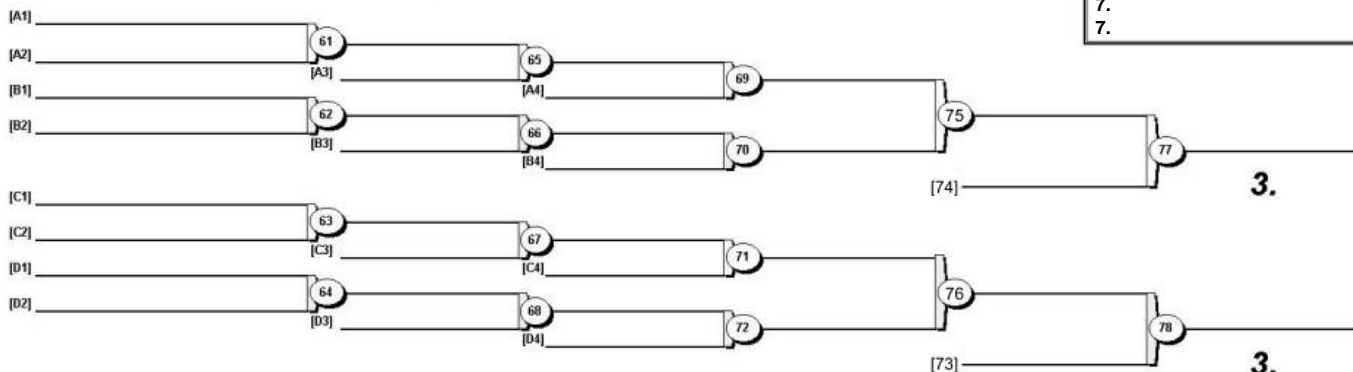



# Cadet European Judo Cup Győr 2017

(HUN Győr, 1819 Nov. 2017)

## -81 kg

28 Judoka

POOL A

1 BOROS, Ivan HUN 1 BOROS, Ivan  
17

9 SVICEVIC, PETAR SRB 2  
25 MEYER, Jan-Marek GER

5 BEZDEK, Martin CZE 3  
21 BERTOK, Krisztofer HUN

13 PANAITE, Alexandru ROU 4  
29 SCHARFETTER, Thomas AUT

17

18

25

Pool A - Winner  
Vainqueur / Sieger

37

POOL B

3 ELEZ, Vuk BIH 5 ELEZ, Vuk  
19

11 FEJER, Richard HUN 6  
27 RUTTKAY, Miroslav SVK

7 ADAMCHUK, Ihor UKR 7  
23 ROTT, Artur GER

15 STOICA, Riccardo ROU 8  
31 HUSZAR, Gergely HUN

19

20

26

Pool B - Winner  
Vainqueur / Sieger

43

POOL C

2 VLCEK, Zbynek CZE 9 VLCEK, Zbynek  
18

10 NAGL, Andreas AUT 10  
26 MILENOVIC, Zoran SRB

6 HARM, Paul GER 11  
22 PRIILINN TURK, Karl EST

14 TOPALA, Vlad ROU 12  
30 VERES, Marcell HUN

21

22

27

Pool C - Winner  
Vainqueur / Sieger

1.

38

POOL D

4 BAJCSEV, Tamas HUN 13 BAJCSEV, Tamas  
20

12 HOELLWART, Moritz AUT 14  
28 KUJAWA, Jan POL

8 SMEULDERS, Elias BEL 15  
24 LUDOSKI, Dusan SRB

16 BORSOS, Kristof HUN 16  
32 CRET, Alex ROU

23

24

28

Pool D - Winner  
Vainqueur / Sieger

Results  
Résultat / Platzierungen

- 1.
- 2.
- 3.
- 3.
- 5.
- 5.
- 7.
- 7.

Repechage / Trostrunde

[A1] \_\_\_\_\_ 29 \_\_\_\_\_ 33  
[A2] \_\_\_\_\_ [A3]

[B1] \_\_\_\_\_ 30 \_\_\_\_\_ 39  
[B2] \_\_\_\_\_ [B3]

[38]

3.

[C1] \_\_\_\_\_ 31 \_\_\_\_\_ 35  
[C2] \_\_\_\_\_ [C3]

[D1] \_\_\_\_\_ 32 \_\_\_\_\_ 40  
[D2] \_\_\_\_\_ [D3]

[37]

3.





# Cadet European Judo Cup Győr 2017

(HUN Győr, 18-19 Nov. 2017)

## -90 kg

19 Judoka

POOL A

1 TOTH, Csaba HUN

1 TOTH, Csaba

9 IONASCIUC, Cristian ROU

2 IONASCIUC, Cristian

5 EDERER, Klaus AUT

3 EDERER, Klaus

13 WACZULIK, Daniel HUN

4

3 VEG, Zsombor HUN

5 VEG, Zsombor

11 VUJOVIC, Mihajlo SRB

6 VUJOVIC, Mihajlo

7 VLADOV, Borislav BUL

7 VLADOV, Borislav

15 TURC, David ROU

8 TURC, David

POOL B

POOL C

2 TURAC, Denis SVK

9 TURAC, Denis

10 MOSER, Moritz AUT

10

6 TURANSZKI, Zalan HUN

11 TURANSZKI, Zalan

14 MAYDANYK, Nikita UKR

12 MAYDANYK, Nikita

POOL D

4 GROMOV, Aliaksei BLR

13 GROMOV, Aliaksei

12 RACA, Roberto CRO

14

8 GRAFFY, Milan HUN

15 GRAFFY, Milan

16 PAZIEWSKI, Mikolaj POL

16 PAZIEWSKI, Mikolaj

Pool A - Winner  
Vainqueur / Sieger

Pool B - Winner  
Vainqueur / Sieger

Pool C - Winner  
Vainqueur / Sieger

Pool D - Winner  
Vainqueur / Sieger

1.

Results  
Résultat / Platzierungen

- 1.
- 2.
- 3.
- 3.
- 5.
- 7.
- 7.

Repechage / Trostrunde

[A1]

[A2]

[B1]

[B2]

[C1]

[C2]

[D1]

[D2]

29

[A3]

30

[B3]

31

[C3]

32

[D3]

33

34

35

36

[38]

[37]

39

40

41

42

3.

3.



# Cadet European Judo Cup Gyor 2017

(HUN Gyor, 1819 Nov. 2017)

## +90 kg

10 Judoka

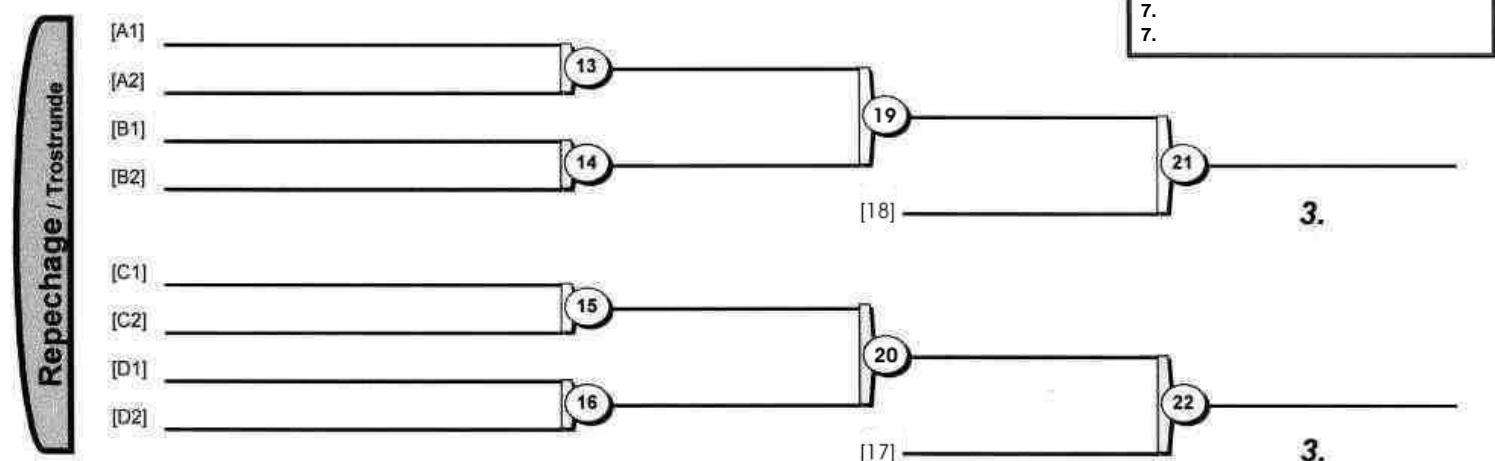
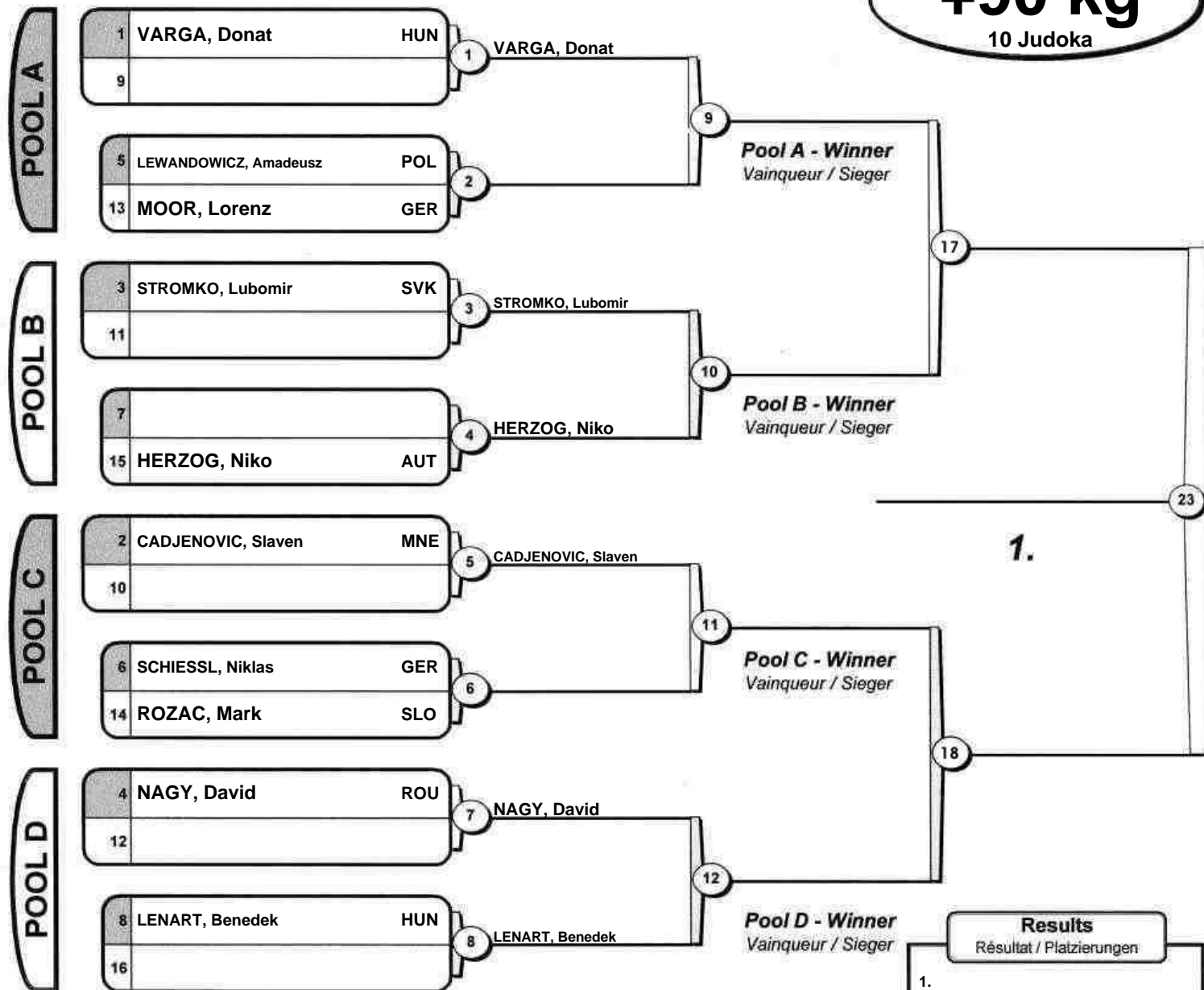





# Cadet European Judo Cup Gyor 2017

(HUN Gyor, 1819 Nov. 2017)

## -40 kg

2 Judoka

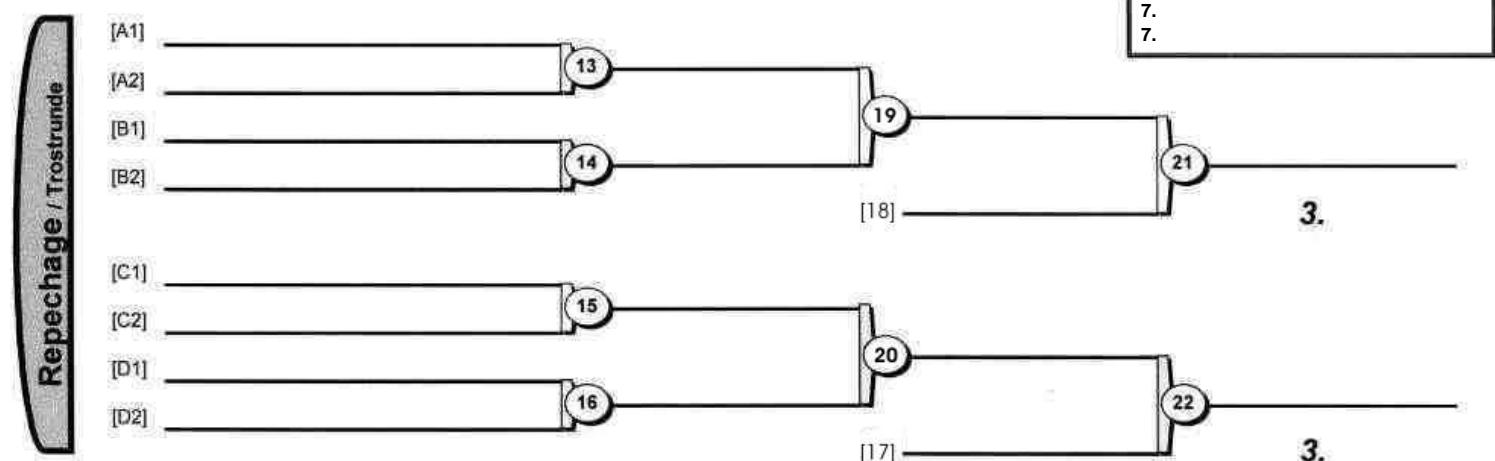
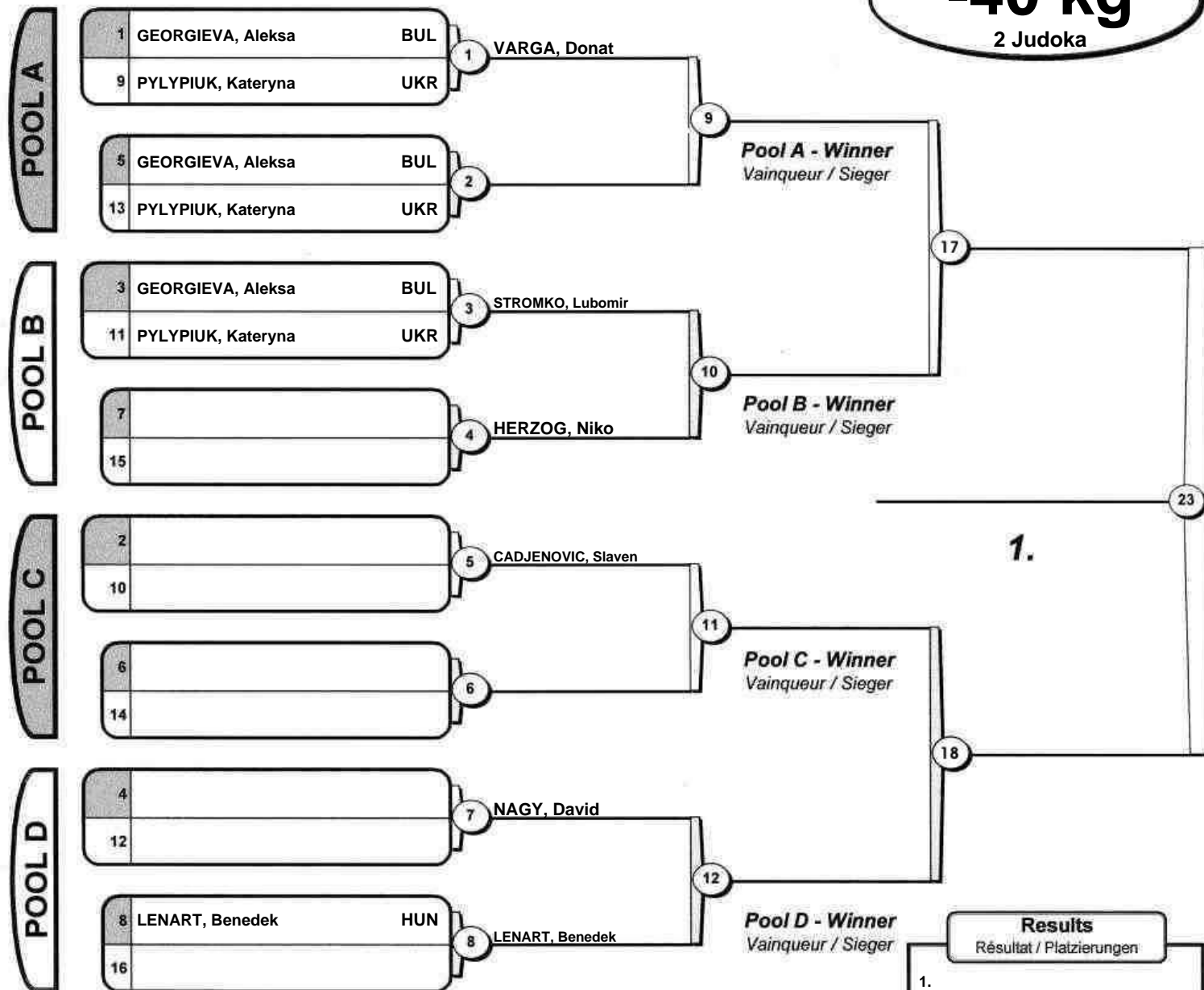



# Cadet European Judo Cup Gyor 2017

(HUN Gyor, 1819 Nov. 2017)

## -44 kg

11 Judoka

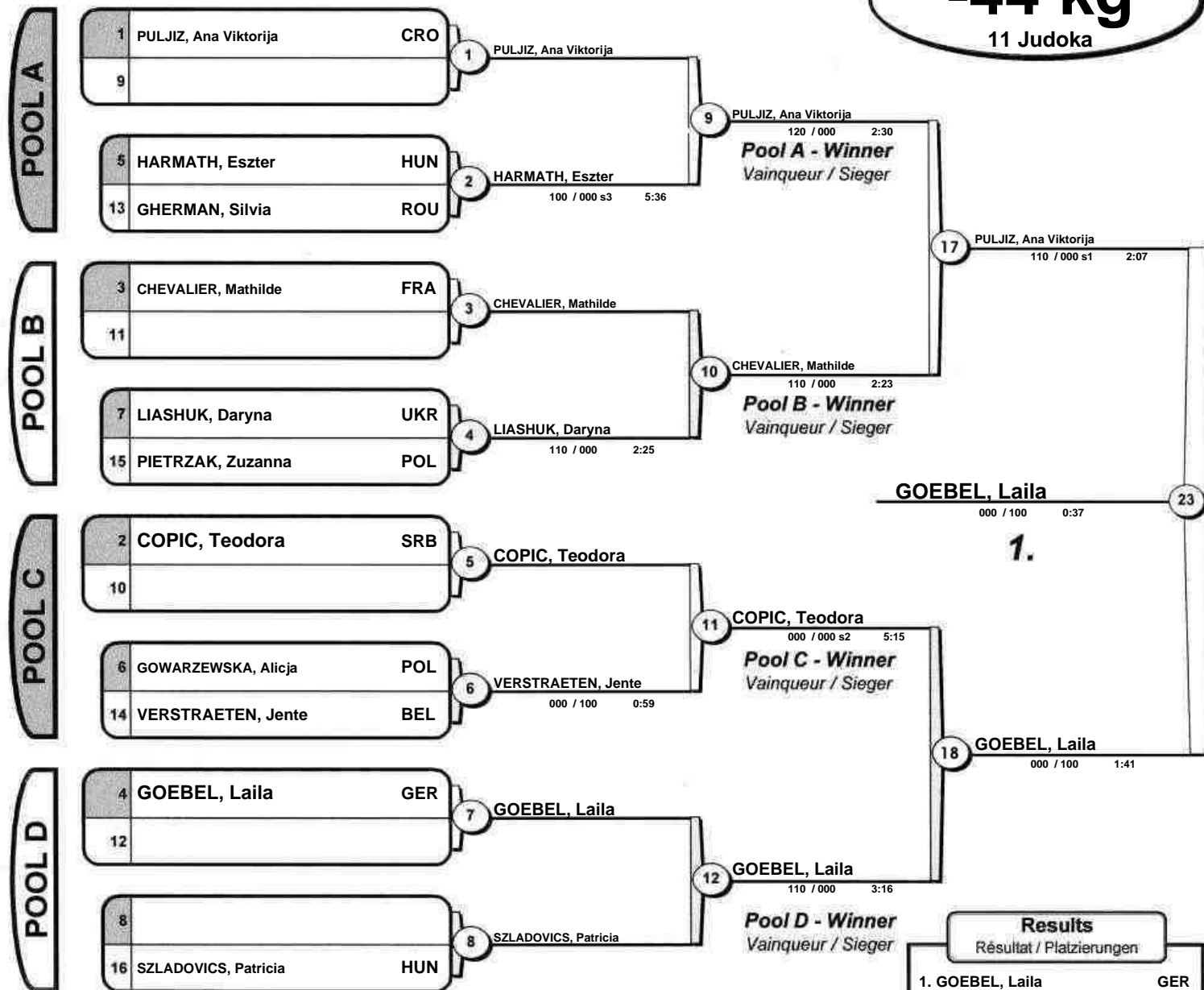

Results	
Résultat / Platzierungen	
1. GOEBEL, Laila	GER
2. PULJIZ, Ana Viktorija	CRO
3. COPIC, Teodora	SRB
3. VERSTRAETEN, Jente	BEL
5. LIASHUK, Daryna	UKR
5. CHEVALIER, Mathilde	FRA
7. HARMATH, Eszter	HUN
7. SZLADOVICS, Patricia	HUN

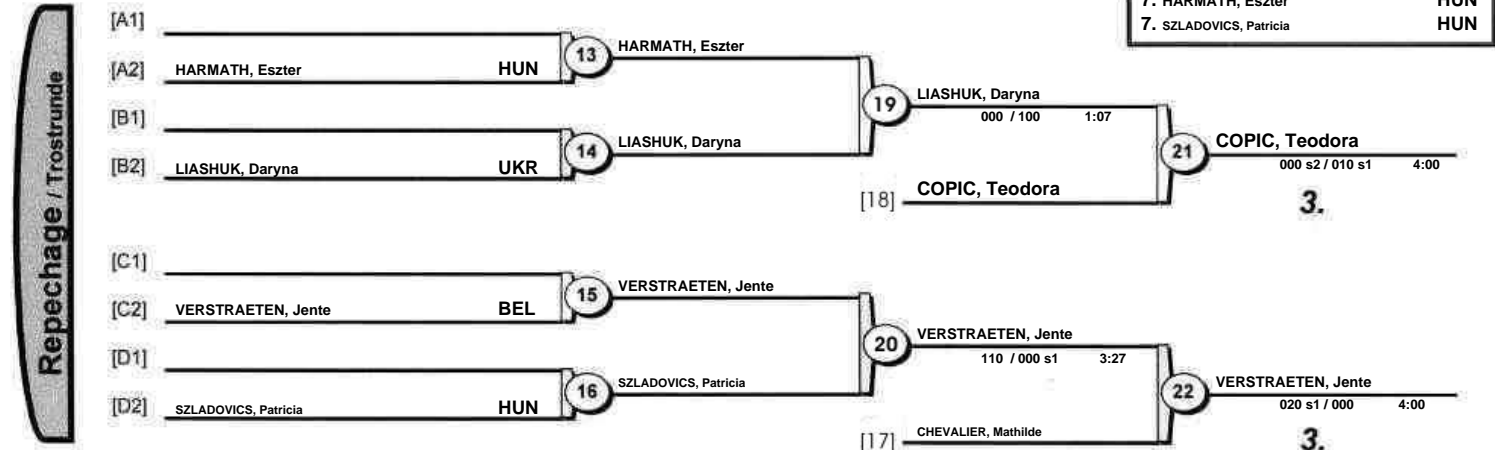



# Cadet European Judo Cup Gyor 2017

(HUN Gyor, 1819 Nov. 2017)

## -48 kg

14 Judoka

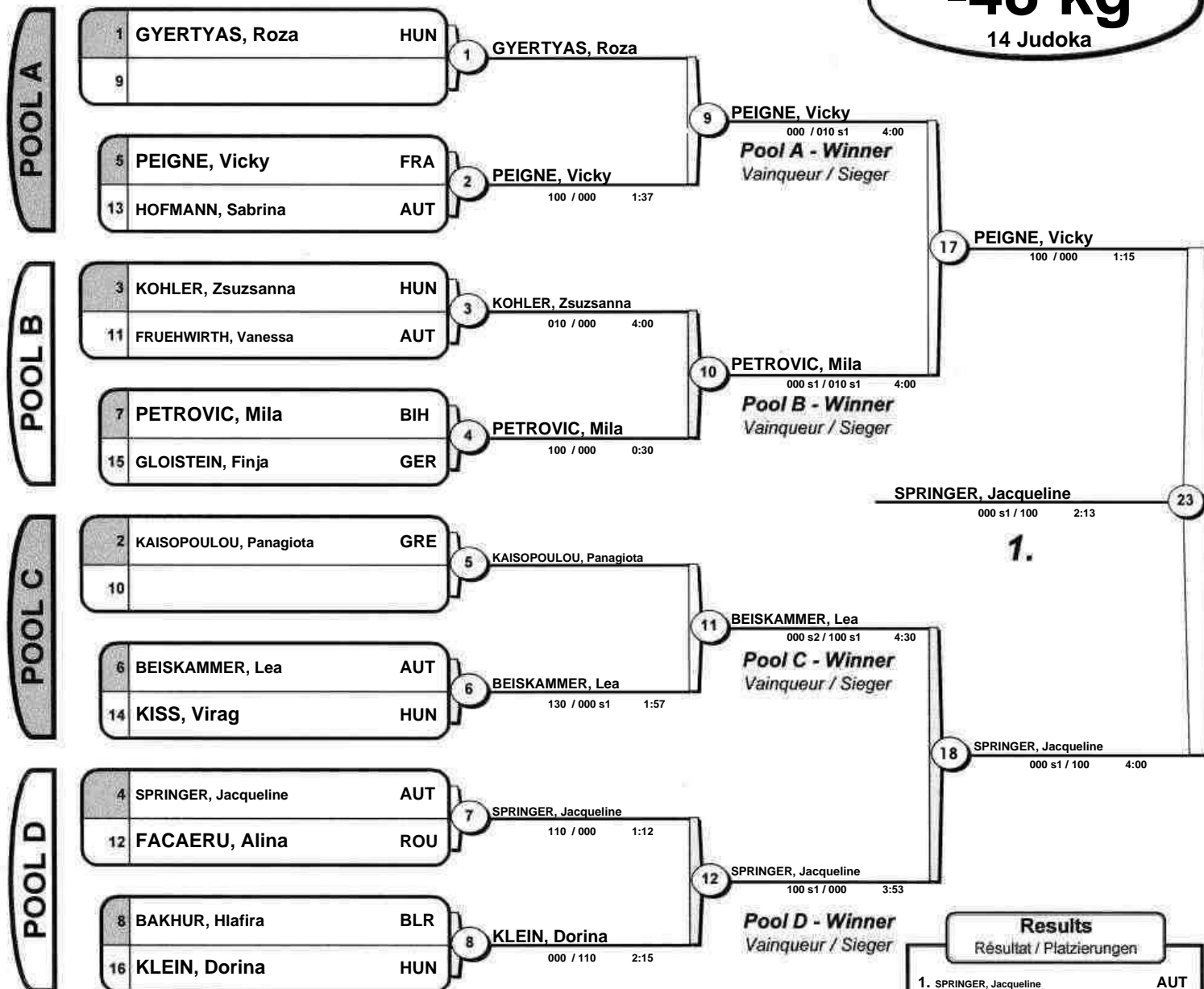

1.

Results	
Résultat / Platzierungen	
1.	SPRINGER, Jacqueline AUT
2.	PEIGNE, Vicky FRA
3.	BEISKAMMER, Lea AUT
3.	KLEIN, Dorina HUN
5.	GYERTYAS, Roza HUN
5.	PETROVIC, Mila BIH
7.	KOHLER, Zsuzsanna HUN
7.	KAISOPOULOU, Panagiota GRE

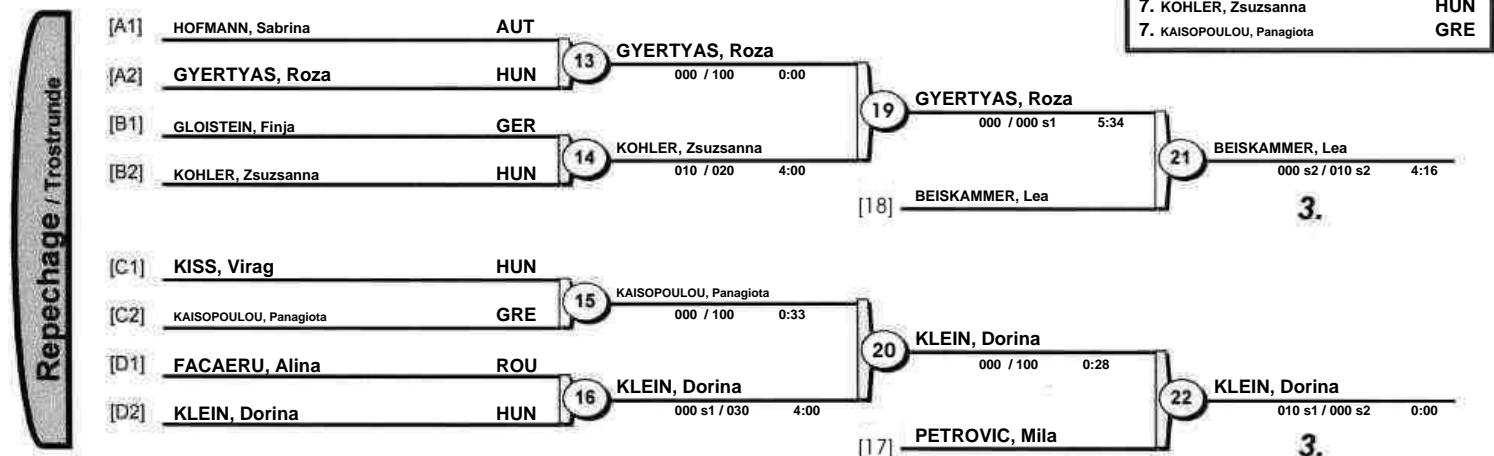





# Cadet European Judo Cup Gyor 2017

(HUN Gyor, 1819 Nov. 2017)

## -52 kg

22 Judoka

POOL A

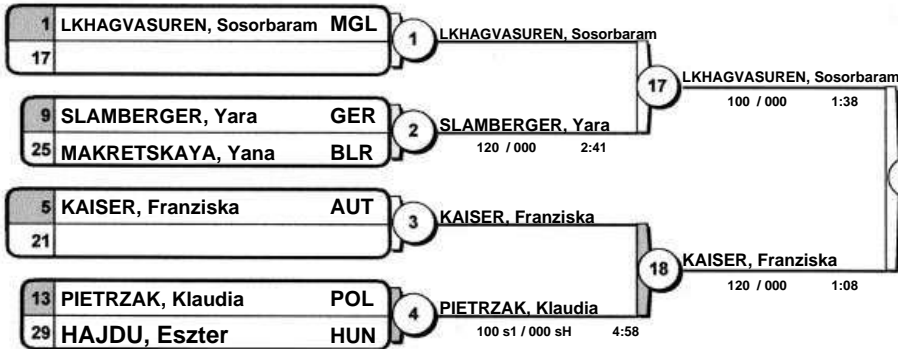

**Pool A - Winner**  
Vainqueur / Sieger

POOL B

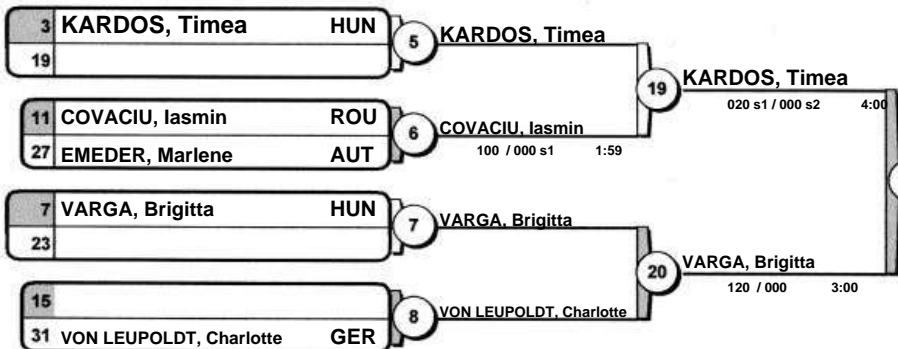

**Pool B - Winner**  
Vainqueur / Sieger

POOL C

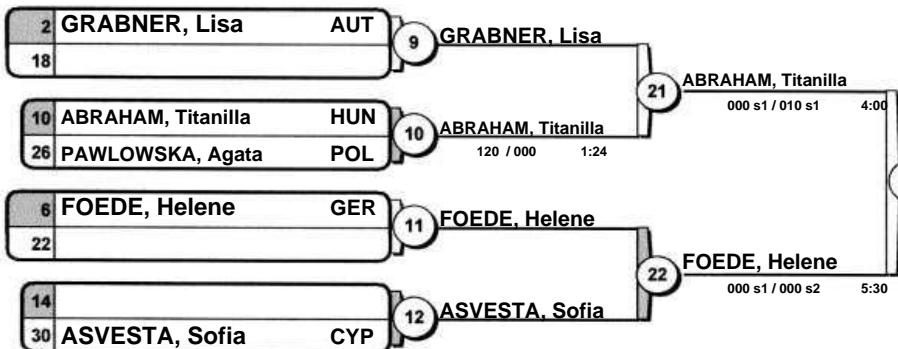

**Pool C - Winner**  
Vainqueur / Sieger

POOL D

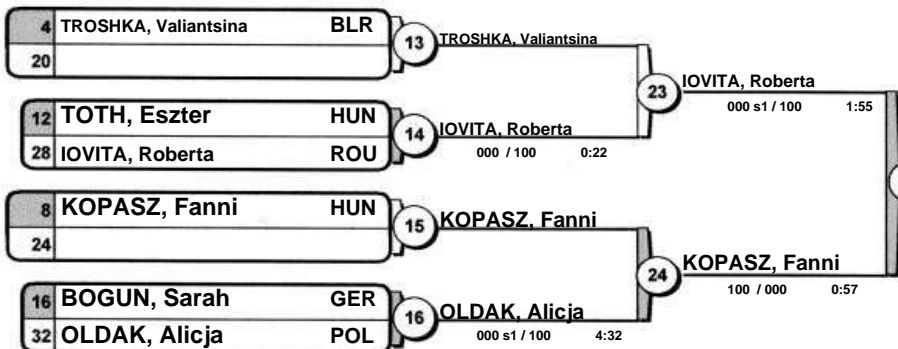

**Pool D - Winner**  
Vainqueur / Sieger

KOPASZ, Fanni

1.

38 KOPASZ, Fanni

**Results**  
Résultat / Platzierungen

1. KOPASZ, Fanni HUN
2. VARGA, Brigitta HUN
3. LKHAGVASUREN, Sosorbaram MGL
3. KAISER, Franziska AUT
5. ABRAHAM, Titanilla HUN
5. IOVITA, Roberta ROU
7. KARDOS, Timea HUN
7. FOEDE, Helene GER

Repechage / Trostrunde

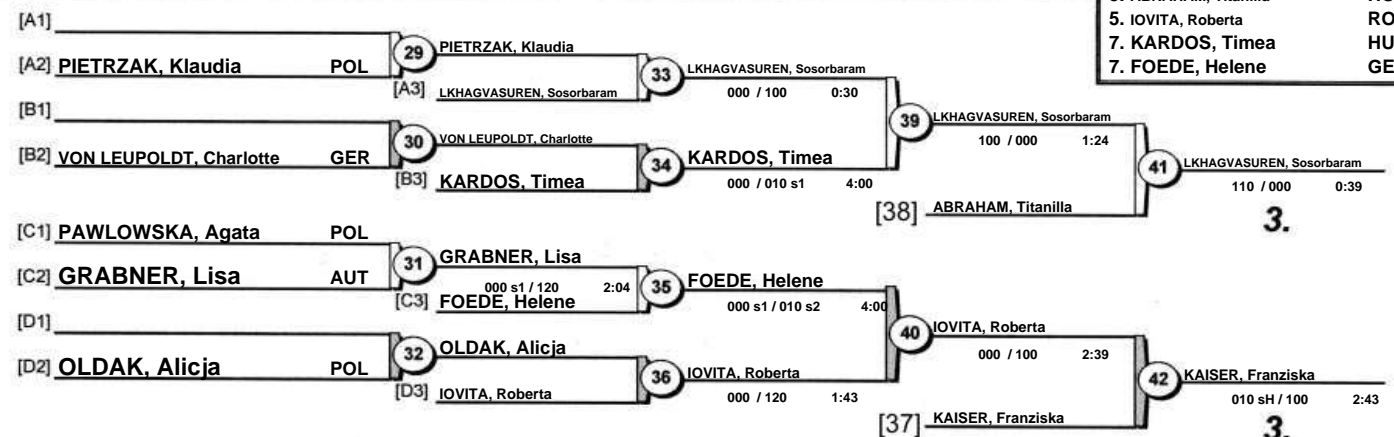

3.

3.



# Cadet European Judo Cup Győr 2017

(HUN Győr, 1819 Nov. 2017)

## -57 kg

20 Judoka

POOL A

1	MAROTI, Alexandra	HUN	1	MAROTI, Alexandra
17			17	
9	KWIATEK, Karina	POL	2	KWIATEK, Karina
25			25	
5	KAYSER, Jasmin	GER	3	KAYSER, Jasmin
21			18	
13	AVRAM, Iulia	ROU	4	AVRAM, Iulia
29			4	

Pool A - Winner  
Vainqueur / Sieger

POOL B

3	LACKNER, Magdalena	AUT	5	LACKNER, Magdalena
19			19	
11	MAKSZEM, Boglarka	ROU	6	MAKSZEM, Boglarka
27			26	
7	KALLINGER, Laura	AUT	7	KALLINGER, Laura
23			20	
15	KARMAN, Andrea	HUN	8	
31	MATUSZEK, Aleksandra	POL	8	

Pool B - Winner  
Vainqueur / Sieger

POOL C

2	TRINACTA, Anna	CZE	9	TRINACTA, Anna
18			21	
10	LOGOZNA, Zuzanna	POL	10	LOGOZNA, Zuzanna
26			27	
6	DARIDA, Blanka	ROU	11	DARIDA, Blanka
22			22	
14	KOLOSA, Michelle	AUT	12	
30	PERGER, Ivett	HUN	12	

Pool C - Winner  
Vainqueur / Sieger

POOL D

4	POPOVIC, Andjela	SRB	13	POPOVIC, Andjela
20			23	
12	WOESS, Rosalie	AUT	14	
28	FOLGER, Viktoria	GER	14	
8	PALKA, Agata	POL	15	PALKA, Agata
24			24	
16	IVANESCU, Florentina	ROU	16	
32	KOVESI, Karina	HUN	16	

Pool D - Winner  
Vainqueur / Sieger

1.

Results  
Résultat / Platzierungen

- 1.
- 2.
- 3.
- 3.
- 5.
- 7.
- 7.

Repechage / Trostrunde

[A1]		29		33			
[A2]			[A3]				
[B1]					39		
[B2]		30		34		41	
			[B3]				
[C1]					[38]		3.
[C2]		31		35			
[C3]			[C3]				
[D1]					40		
[D2]		32		36		42	
[D3]			[D3]				
					[37]		3.



# Cadet European Judo Cup Győr 2017

(HUN Győr, 1819 Nov. 2017)

## -63 kg

17 Judoka

POOL A

1	BRANCHEVA, Lidia	BUL	1	BRANCHEVA, Lidia
17			17	
9	DE BOOR, Eszter Maria	GER	2	DE BOOR, Eszter Maria
25			25	
5	TANDI, Alexa	HUN	3	TANDI, Alexa
21			18	
13			4	AMARANTIDOU, Ioanna
29	AMARANTIDOU, Ioanna	GRE	4	AMARANTIDOU, Ioanna

Pool A - Winner  
Vainqueur / Sieger

POOL B

3	SKIPIALA, Michalina	POL	5	SKIPIALA, Michalina
19			19	
11			6	KATZENMAJER, Kira
27	KATZENMAJER, Kira	HUN	6	KATZENMAJER, Kira
7	FRIEDE, Luise	GER	7	FRIEDE, Luise
23			20	
15	LEITINGER, Alina	AUT	8	LEITINGER, Alina
31			8	LEITINGER, Alina

Pool B - Winner  
Vainqueur / Sieger

POOL C

2	KRISTO, Katarina	CRO	9	KRISTO, Katarina
18			21	
10	BEYERSDORF, Leonie	GER	10	BEYERSDORF, Leonie
26			27	
6	SPYROPOULOU, Zoe	GRE	11	SPYROPOULOU, Zoe
22			22	
14	SOBIERAJSKA, Katarzyna	POL	12	
30	GECSEI, Dorottya	HUN	12	

Pool C - Winner  
Vainqueur / Sieger

POOL D

4	BAJCSEV, Vivien	HUN	13	BAJCSEV, Vivien
20			23	
12			14	MARTINEK, Evelyn
28	MARTINEK, Evelyn	AUT	14	MARTINEK, Evelyn
8	STOLZE, Friederike	GER	15	STOLZE, Friederike
24			24	
16	HEGEDUS, Hanga	HUN	16	HEGEDUS, Hanga
32			16	HEGEDUS, Hanga

Pool D - Winner  
Vainqueur / Sieger

1.

Results  
Résultat / Platzierungen

- 1.
- 2.
- 3.
- 3.
- 5.
- 7.
- 7.

Repechage / Trostrunde

[A1]		29		33			
[A2]			[A3]				
[B1]		30		34		39	
[B2]			[B3]				41
[C1]		31		35		[38]	3.
[C2]			[C3]				
[D1]		32		36		40	
[D2]			[D3]				42
						[37]	3.







# Cadet European Judo Cup Gyor 2017

(HUN Gyor, 1819 Nov. 2017)

## +70 kg

10 Judoka

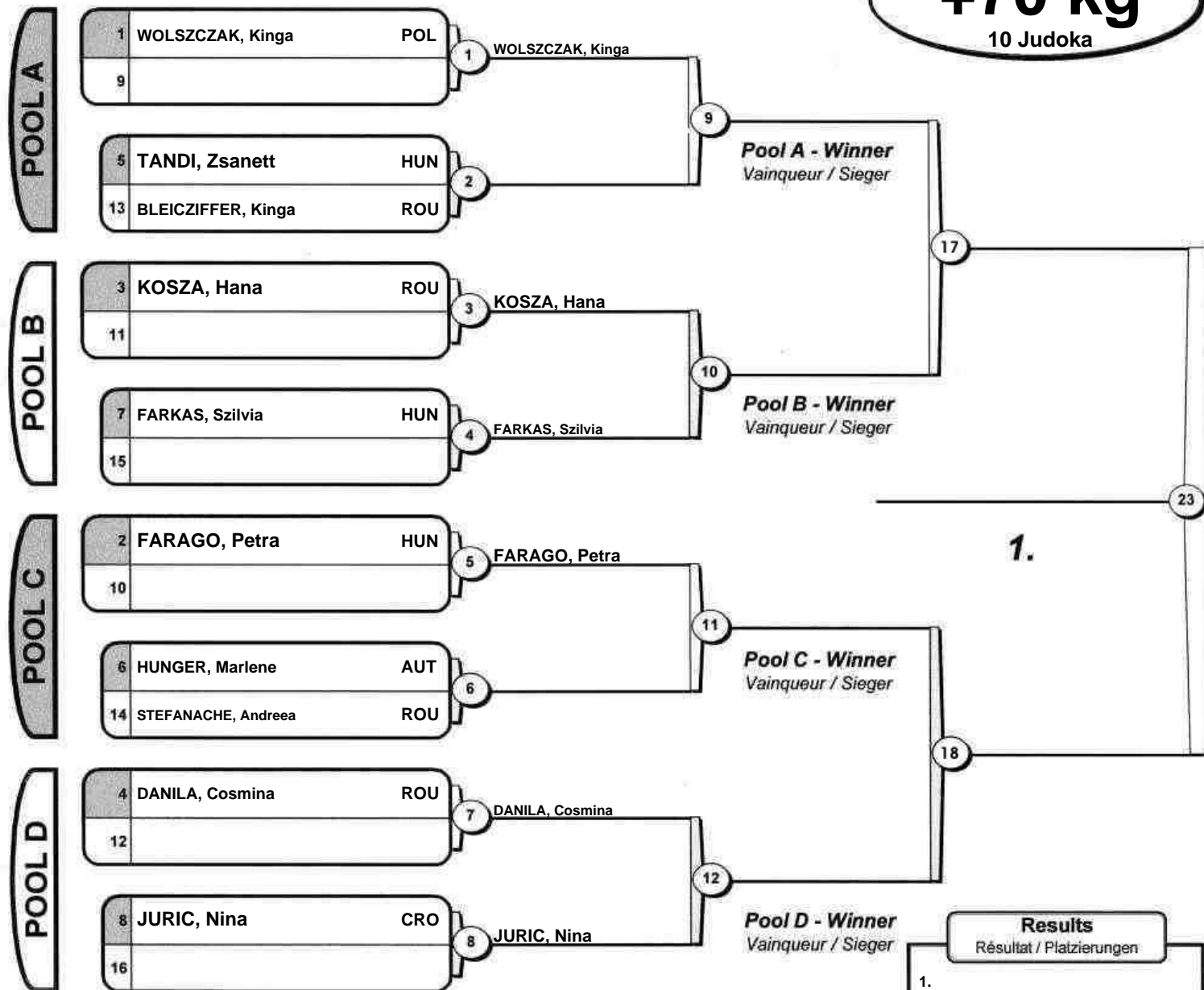

Results	
Résultat / Platzierungen	
1.	
2.	
3.	
3.	
5.	
5.	
7.	
7.	

